

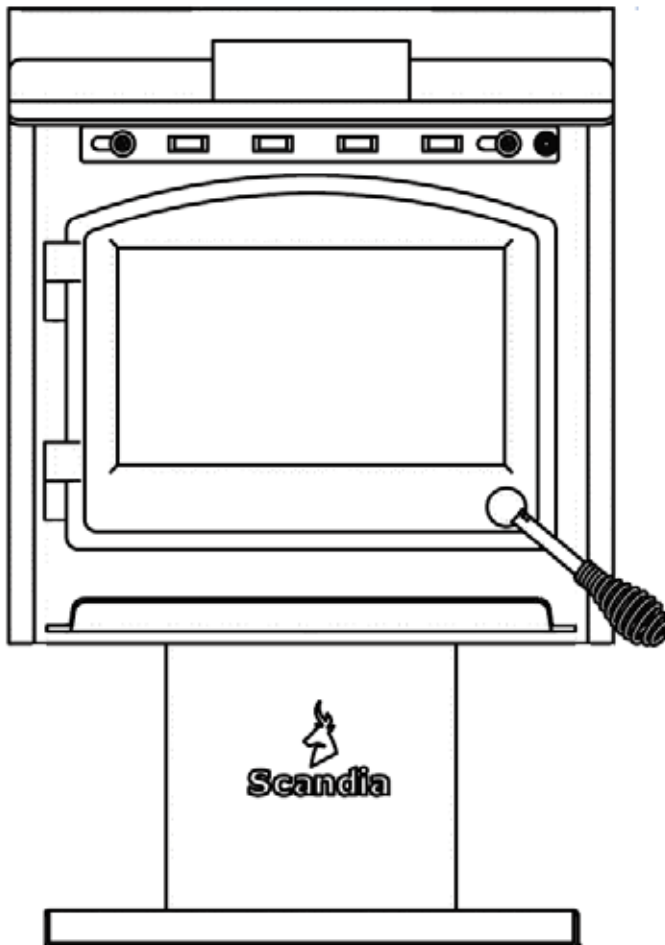

Scandia

WARMBRITE 140LE

OWNERS MANUAL



Warmbrite 140LE

Version 2.3

Contents of manual may be updated without notice.
For the latest version of this manual please refer to our website: www.scandiastoves.co.nz

Scandia Heating (Aust) Pty Ltd

Head Office
58-62 Access Way
Carrum Downs VIC 3201
Australia

1300 432 837
info@scandiastoves.com.au
www.scandiastoves.co.nz

SCANDIA WARMBRITE RANGE

Model Name	Model Number
Warmbrite 140LE	SCWB140LE

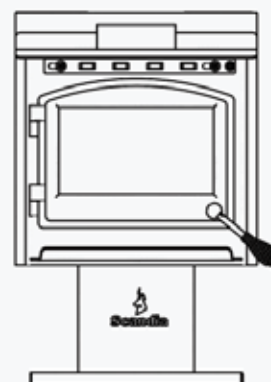

CONTENTS

Wood fire safety	2
Before installing your wood fire	3
Installation	4
Operating your wood fire	9
Wood fire maintenance	11
Trouble shooting	13
Warranty	14
Exploded diagram / Spare parts list	16

INTRODUCTION

Congratulations on purchasing a genuine Scandia Wood fire. When cared for properly, these high quality, finely crafted wood fires will offer many years of reliable performance. This instruction manual has been developed to ensure optimum performance from your Scandia wood fire. It's very important that you thoroughly read and understand all instructions before using your new wood fire.

COUNCIL REQUIREMENTS

Check Local Council Requirements Eg. permits

When installing, operating and maintaining your wood fire, follow the guidelines presented in these instructions, and make them available to anyone using or servicing the wood fire.

Your city, town, state or region may require a building permit to install a solid fuel burning appliance.

Always consult your local building inspector or local council to determine what regulations apply in your area.



Please note:

Your wood fire must be installed by a qualified person whose work conforms with local council regulations, Australia and New Zealand standards & manufacturers recommendations. Failure to do so will void your warranty and could possibly void any home insurance.

WOOD FIRE SAFETY

When properly maintained and operated your wood fire should give you many years of service, however there are important safety aspects of these products that you need to be aware of when operating a wood fire.

-
1. This appliance is not intended for use by persons (including children) with reduced physical, sensory or mental capabilities, or lack of experience and knowledge, unless they have been given supervision or instruction concerning use of the appliance by a person responsible for their safety.
-
2. Children should be supervised to ensure that they do not play with the appliance.
-
3. Never place combustible items such as but not limited to furniture, fabric or wood within the specified clearances to combustibles.
-
4. The burning of wood gives off gases which can be extremely dangerous. Wood fires are designed so that under normal operating circumstances these gases pass up the flue chimney system and cannot escape into your home, however it is important that your flue system is properly installed and that you check all joints regularly to ensure that there are no cracks or gaps, check the door sealing rope and replace when damaged/worn. We recommend a smoke alarm be fitted in rooms where wood fires are installed. Do not use your wood fire in a room where negative pressure conditions exist. Negative pressure environments can cause products of combustion to be drawn from the fireplace into the room. Caution should be taken when using any form of extraction in a room where a wood fire is installed.
-
5. This appliance is designed to specifically burn dry softwood. Do not burn rubbish, driftwood, flammable liquids or any substance containing salts or corrosives.
-
6. Creosote and soot may accumulate in your flue pipe and chimney. This may ignite, causing a chimney fire. If you suspect a chimney fire close down the air controls on the wood fire, if the fire persists evacuate people from the building and call the Fire Brigade. To prevent the accumulation of soot or creosote, check flue and chimney regularly and clean as necessary. Good burning, hot wood fires will generally cause a lot less build-up than slow burning wood fires, likewise dry wood will cause less build-up than wet wood. We recommend a fire extinguisher be available where wood fires are in operation. In the event of a chimney fire do not re-light the wood fire until the fire and the flue chimney system have been thoroughly checked and repaired/replaced as necessary.
-
7. Wood fires get extremely hot and should not be touched when lit. When young children are in the area, we recommend the use of a suitable fire guard around the wood fire. Always wear protective gloves when reloading wood fire.
-
8. Never over-fire your wood fire. If external parts of your wood fire are glowing red then the wood fire is over-firing and your draught settings should be reduced. Never interfere with the draught mechanisms or adjust your air settings outside those limits set when the wood fire is manufactured. Never use a secondary fan to supply or extract air to the wood fire.
-
9. All users of the wood fire should be aware of the contents of this manual. Please leave this manual where it is accessible to wood fire users and do not allow anyone to use the wood fire that is unfamiliar with its correct operation.
-
10. Never use the wood fire if any parts are missing or damaged, only use genuine parts as replacements. Never modify your wood fire.

BEFORE INSTALLING YOUR WOOD FIRE

You need to consider the following to ensure the safe operation of your wood fire:

- Provision of adequate air to support efficient combustion of the fuel.
- A well sealed flue/chimney system, hereinafter referred to as the “flue system”.
- The protection of combustible materials in proximity of the wood fire.
- A suitable base on which to place your wood fire.

ADEQUATE PROVISION AIR

It is essential for the safe and efficient use of your wood fire that you provide an adequate air supply to your wood fire.

This may mean the provision of an outside air supply to the room, especially if there are extraction units such as cooker hoods or clothes dryers in the vicinity. Failure to do so will mean that fuel is burned inefficiently causing smoke, blackening the glass and may also cause smoke to come back into the room. As a simple check for this open a door or window in the room and check if the wood fire burns more efficiently.

WELL SEALED FLUE SYSTEM

Under no circumstances should you use aluminum or galvanized steel pipes for your wood fire flue. Always fit pipes with the narrow crimped side down, this allows any creosote to run down the inside of the pipe and not to come out and cause an unsightly mess and possible fire hazard.

Pipe bends should be kept to a minimum and we do not recommend using more than 2 bends on any installation. Flues must not pass through ceilings, floors, attics, roofs, or combustible walls without adequate and approved insulation being provided to protect combustible materials.

The chimney and flue provide a means of taking combusted fuel from the wood fire, as well as a draught to enable the wood fire to work. It is essential that the flue system is kept in good condition and there are no breaks or cracks allowing contact with any other combustible materials of the house. It is also essential that the flue system is kept clean and seals are maintained to ensure the draught is not lost.

The open end of the flue system must be above the height of the apex of the building and any other obstructions, such as trees, which are within 3 meters (10ft) of the flue system. Failure to do this will affect the efficiency of the wood fire and may cause down draughts which will mean dangerous products of combustion are emitted into the room.

Under no circumstances should the flue pipe be less than 6” (152mm) internal diameter.

CLEARANCES TO COMBUSTIBLES

It is extremely important that you respect required installation distances and that you respect local installation regulations.

This is for your safety! The manufacturer is not responsible for the product, if it is not installed following these recommendations. These clearances may only be reduced by means approved by the regulatory authority.

A combustible surface is anything that can burn (i.e. plaster, wall paper, wood, fabrics etc.) These surfaces are not limited to those that are visible and also include materials that are behind non-combustible materials. If you are not sure of the combustible nature of a material, consult your local fire officials.

HEARTH REQUIREMENTS

A minimum 820mm deep x 750mm wide x 6mm thick floor protector (compressed board) should be used under and in front of the appliance base when installing the appliance (see joint AS/NZS 2918:2018 3.3.2). The floor protector should extend 300mm in front of the appliance door and be placed centrally in the 750mm width. The Thermal resistivity of the floor protector is 0.026m².K/W for 6mm thick compressed board sheets.

SEISMIC RESTRAINT OF THE WOOD FIRE AND FLOOR PROTECTOR:

Your appliance must be seismically restrained, including the floor protector using the provided holes or brackets. The restraints shall be capable enough of resisting a seismic loading equal to 0.4 times the mass of the appliance. We recommend a minimum of 8mm dynabolts on concrete floors and 8mm coach screws for wooden floors, of appropriate length.

INSTALLATION

CLEARANCES TO COMBUSTIBLES

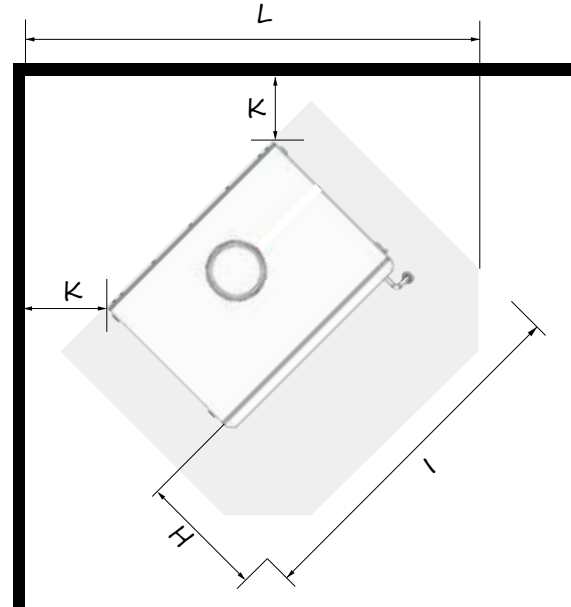
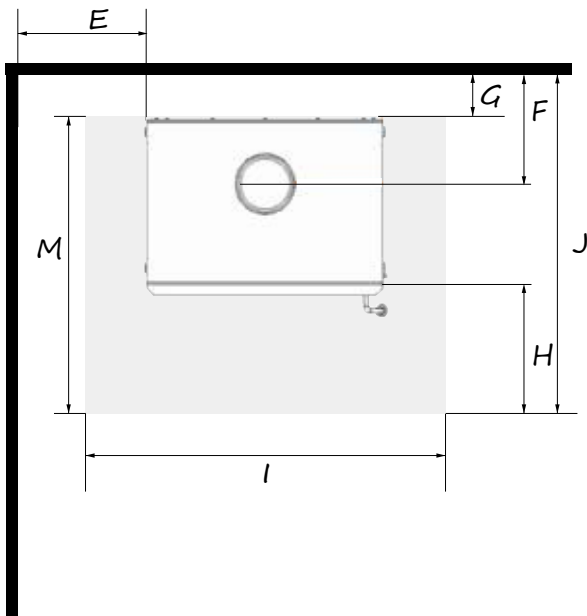

SCWB140LE

E	Side of fire to side wall	475
F	Centre of fire flue to rear wall	225
G	Rear of fire to rear wall	100
H	Front of fire to hearth front	300
I	Minimum hearth width	750
J	Minimum hearth depth	840
K	Rear corner of fire to wall	200
L	Minimum Corner Hearth Depth	1075

All measurements are in 'mm'. When using Scandia HeatMax Flue Kit

Manufacturers recommendation: Keep all combustible materials at least 1.22 metres (4 feet) away from the appliance. This include rugs, fabrics, furnishings, papers, firewood, etc. NEVER dry clothing on or within 1.22 metres of the appliance.

INSTALLATION ...continued

FOR CONNECTING INTO A STANDARD INSTALLATION USING SCANDIA HEATMAX FLUE KITS

The following drawing is meant as a guide only. Your wood fire must be installed by a qualified person whose work conforms with local council regulations, Australian/New Zealand standards (AS/NZS 2918:2001) & manufacturers recommendations.

Scandia wood fires are independently tested to Australian/New Zealand standards using a Scandia HeatMax Flue Kit, we always recommend using a Scandia flue kit when installing a Scandia wood fire.

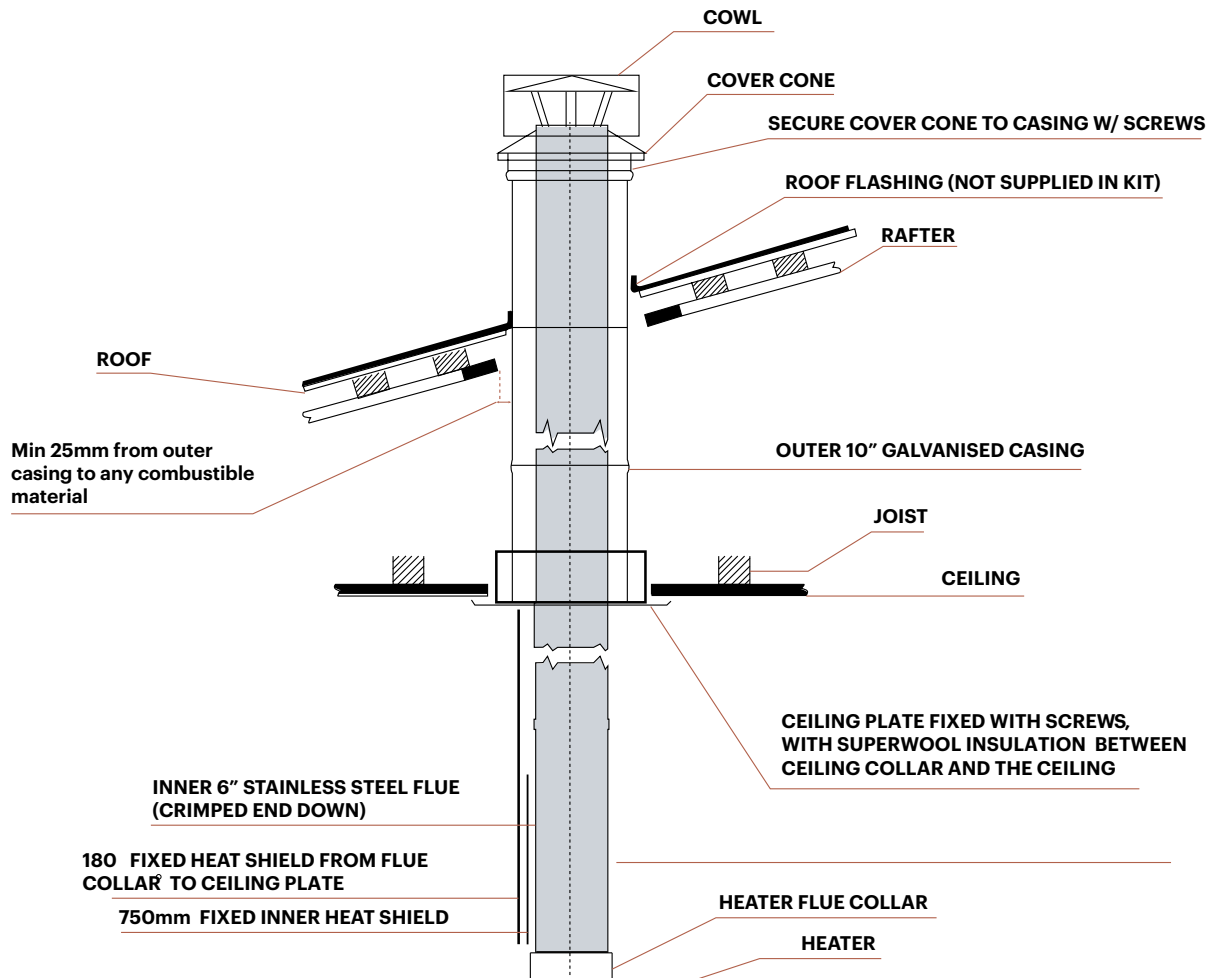

**STANDARD FLAT CEILING HEATMAX
FLUE KIT CONFIGURATION**

1X Flue Kit
Part No. - SG020100019

INSTALLATIONcontinued

FOR CONNECTION INTO A SLOPING CEILING INSTALLATION USING A SCANDIA HEATMAX FLUE KIT AND A HEATMAX ANGLED CEILING KIT

The following drawings are meant as a guide only. Your wood fire must be installed by a qualified person whose work conforms with local council regulations, Australian/New Zealand standards (AS/NZS 2918:2018) and manufacturers recommendations.

Scandia wood fires are independently tested to AS/NZS Standards using a Scandia HeatMax flue kit, we always recommend using a Scandia HeatMax flue kit when installing a Scandia wood fire.

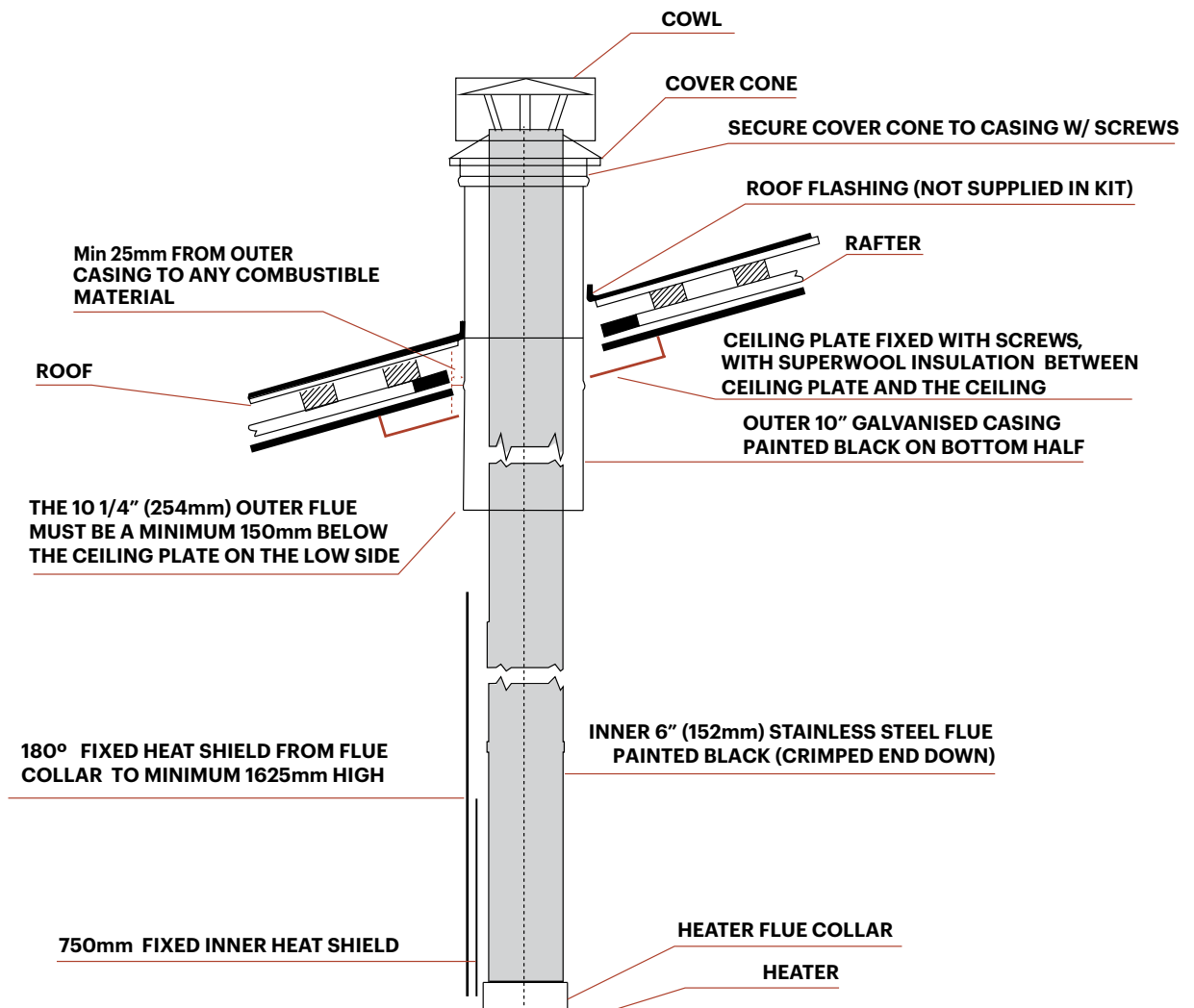

**STANDARD HEATMAX ANGLED
CEILING FLUE KIT CONFIGURATION**

1 X Flue Kit
Part No. - SG020100019
1 X ANGLED CEILING KIT Part No. SG020100020

INSTALLATIONcontinued

This HeatMax Flue Kit is tested and certified to AS/NZS 2918:2001 Appendix F. Installation of any solid fuel appliance should only be carried out by suitably trained and qualified personnel.

STANDARD FLAT CEILING INSTALLATION

Position the wood fire to the desired position, with respect to the manufacturers minimum clearances to combustibles. The installer must check that no roof line ridges or valleys are in the way of the flue systems path, and if they cannot be avoided, then the installer must ensure compliance with local building standards when altering any structural timbers, or they must engage a qualified person to carry out any structural alterations.

1. Use a plum bob to mark the point on the ceiling central to the flue collar on the appliance.
2. Cut a 350mm mm diameter hole in the ceiling with the plumb bob mark as its center.
3. Cut the corresponding hole in the roof material, but only enough to allow the 254mm outer case to pass through.
4. Put the ceiling plate riser assembly into place on top of the ceiling material and fit extra braces between the roof joists.
5. Install the Ceiling plate
Option 1 - For use on Scandia appliances the 2 piece ceiling plate must be used, this is adjustable in depth from 500mm to 375mm. Where possible the ceiling plate should be installed at the full 500mm depth unless interference with cornice or rear wall occurs when abiding by applicable appliances Appendix A or B of AS/NZ 2918. If the ceiling plate is required to be reduced the rear of the ceiling plate must extend fully to cornice or rear wall. To enable reduction in depth it may be necessary to pop out removable sections of the rear piece (Part B Below). Trim the insulation to suit the final size of the ceiling plate, ensure insulation is placed between the ceiling plate and the ceiling.
Option 2 - For use on other brand appliances use the Std 400mm x 400mm ceiling plate in accordance with this kits AS/NZS 2918 Appendix F report no ASTF25003. The appliance must also be installed as per its appropriate AS/NZS 2918 Appendices A or B requirements.
6. Assemble the upper and lower 254mm diameter galvanised flue lengths, ensuring the one with the painted section is on the bottom. The crimped end of the 254mm galvanised length must be at the top.
7. Lower the 254mm galvanised length assembly through the hole in the roofing all the way down so that it sits on the tabs on the Ceiling Ring riser.
Secure the 254mm galvanised casings in this position with angle brackets. (Not supplied) so that there is no weight on the ceiling plate or ceiling material.
8. Assemble the first 2 lengths of 152mm stainless steel flue pipes with the painted sections at the bottom (crimped end down), making sure that the painted length with the small bracket attached is the first one onto the wood fire. Slide the painted heatshield bracket over the top of the top length.
(This will be used later to attach the upper heatshield).
9. Assemble the 2 unpainted 152mm stainless steel flue lengths then attach the flue spacer bracket just above the join of these 2 lengths. This will keep the 152mm inner located centrally in the upper 254mm galvanised casing.
10. At the very top of the assembled flue pipes, ensure that the 152mm stainless steel inner and the 254mm galvanised outer are level. To achieve this one or the other may need to be trimmed. This is done so that the cowl will fit as intended by the manufacturer.
11. Fit the cowl assembly making sure the stainless steel inner on the cowl fits inside the top 152mm stainless steel flue pipe and attach with rivets or screws.
12. Flash to roof with an appropriate product. (Not supplied). Use the 254mm bracket support with angle brackets (Not supplied) or stainless steel wire and turnbuckles (Not supplied) to secure the flue to the roof, especially if the height is more than a metre above the roof material.

PART A

PART B

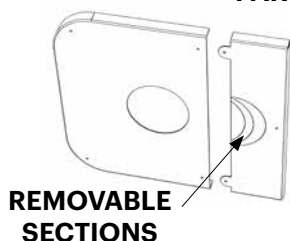

FULLY EXTENDED (500mm x 500mm)

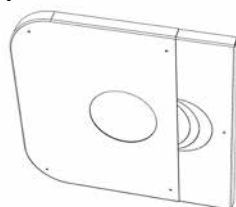

MAXIMUM CLOSED (500mm x 375mm)

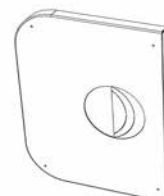

MINIMUM INSTALLATION CLEARANCES

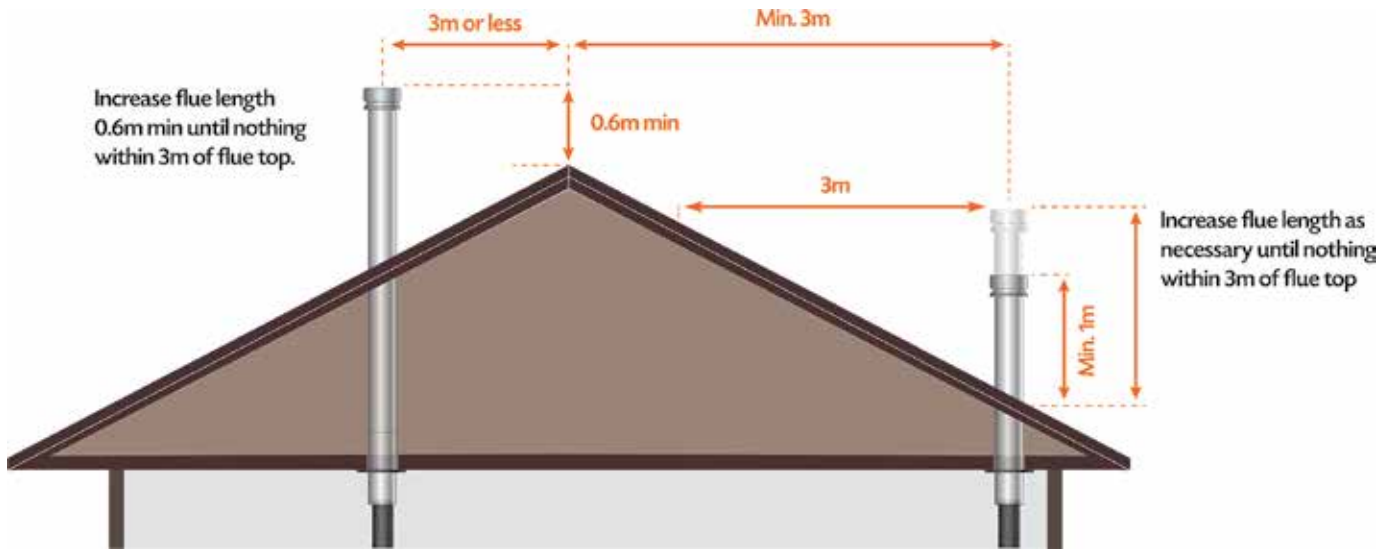

FIGURE 1

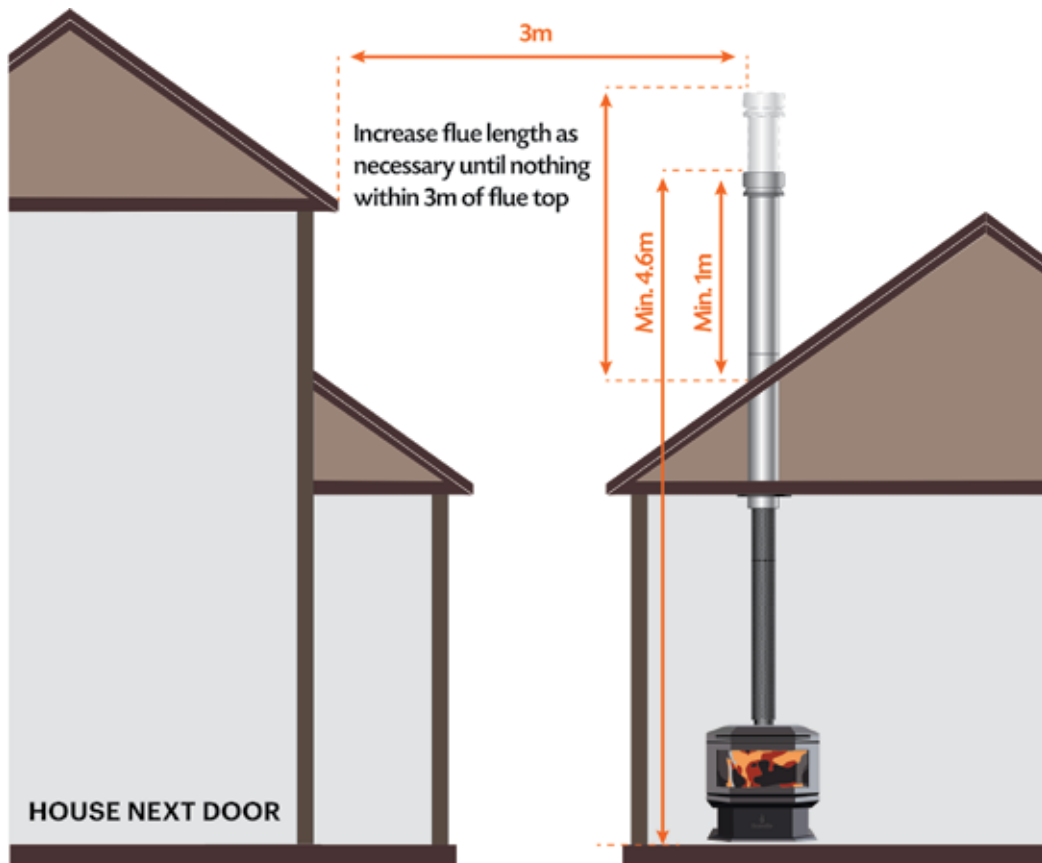

FIGURE 2

INSTALLATIONcontinued

FITTING THE BAFFLE PLATE& FIREBRICKS

1. Remove all loose items from the fire box. First install the top baffle. Place the baffle in the firebox with the bent edges facing the same direction as in the below drawings.
2. Lift the front edge of the baffle up and rest it on the top of the front baffle support lugs, continue to lift the rear of the baffle over the rear lugs, you will need to slide the baffle forward to clear the rear lugs.
3. Once the rear of the baffle is above the rear lugs slide the baffle all the way to the back of the firebox and rest the rear of the baffle on the rear lugs, ensuring the baffle is touching the rear wall of the firebox.
4. Next install the firebricks. First install the side and rear firebricks, place the firebrick retainer in place on the top of the firebricks as shown in the below diagram.
5. Install the base firebricks. Push side firebricks all together leaving any gap at the front of the fire. Push rear firebricks together leaving gaps even on each side. Push base firebricks together leaving even gap around outside.

SCWB140 LE

- | | |
|---|---|
| 1 | Top Baffle |
| 2 | Firebrick Retainer |
| 3 | Firebricks - 230mm x 121mm x 38mm - Qty 8 |
| 4 | Firebrick - 230mm x 121mm x 38mm with notch - Qty 1 |
| 5 | Firebrick - 183mm x 162mm x 25mm - Qty 4 |

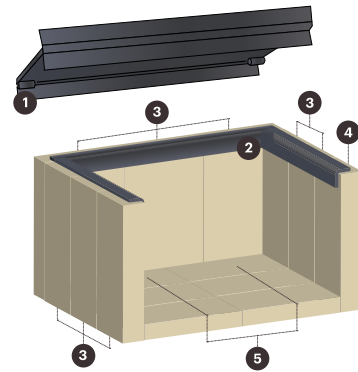

OPERATING YOUR WOOD FIRE

CONTROLS AND THEIR USE

1 Air Slide to control primary air intake

OPEN ← → CLOSED

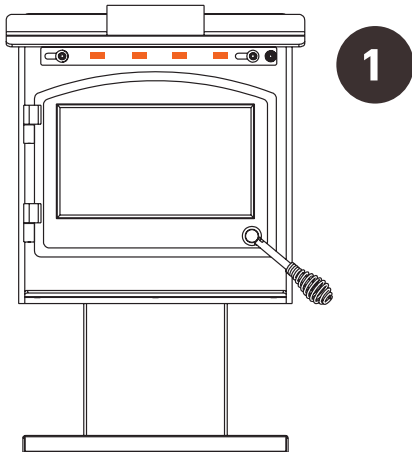

FUEL

Your wood fire is designed to burn dry softwood only.

It is **NOT** designed to burn the following:

- Hardwood
- Treated or painted wood
- Paper or cardboard, other than small amounts used to light stove.
- Plastics
- Synthetic fuel or logs that are not approved for solid fuel stoves
- Household rubbish
- Liquid fuels

Burning these or other products for which the wood fire was not designed may damage the wood fire and cause a fire hazard or release toxic fumes.

Fuel should be stored in a dry place; wood should be dried for at least 1 year and have a moisture content of less than 20%. Wet wood may cause serious creosote build up, which may damage your flue system and even your wood fire. Therefore the use of green, sappy or wet wood is strongly discouraged.

WARNING: FIRST OPERATION OF STOVE



When operating, this unit will get extremely hot. Do Not Touch, use tools where necessary. You should begin using your wood fire by lighting small fires which get progressively larger. We recommend lighting approximately 5 small fires before you put the wood fire into full service. Allow the wood fire to fully cool between each of these fires. There may be some smell and a small amount of smoke from the wood fire during the initial operations. This is perfectly normal and is merely the curing of the wood fire paint. Opening a window or door to provide additional ventilation will help alleviate this.

OPERATING YOUR WOOD FIREcontinued

AIR CONTROLS

Your wood fire needs air to burn the fuel. This air is supplied through a primary air slide at the right side of the front of your wood fire above the door.

Primary air, as the name suggests, is used for the initial burning of the fuel and is also used to keep the stove glass clean.

Secondary air is used for secondary combustion, which makes the stove more efficient and reduces emissions.

The settings of the primary air control very much depends on draught and local conditions and after a few fires, you should have a good idea of the best settings for your wood fire. The air slide control should be fully opened when lighting the fire.

Once the fire is established, the air slide control may be adjusted as required. Reducing the air intake will cause the wood fire to burn slower. This may cause some blackening of the stove glass, but this should burn off once the wood fire is burning brightly again.

LIGHTING THE FIRE

Open the fire door, lay a few crumpled sheets of paper or firelighters on the firebox base then a few small dry pieces of sticks or kindling.

Open the air inlet controls. Now light the paper, close the fire door when the kindling has caught fire (allow about 10 minutes for this to happen) add larger pieces of dry wood, until the fire box is half filled. When the larger pieces of wood have caught fire, add full sized logs. Close the air controls to the point where the required burn rate is obtained.

REFUELING

Before refueling your wood fire, turn the air supply to high for a few moments until there is a good fire in the fire. This will ensure there is no build-up of harmful gases in the wood fire when the door is opened and will also get the new fuel burning quickly and not allow it to kill the fire. Open the door slowly in case any logs or coal have fallen against the glass. Opening the door quickly may result in smoke being drawn into the room.

To reload the wood fire, open the door and feed the fuel in slowly always using either tongs, a small shovel along with protective gloves. Do not overfill the wood fire. It is always better to put in small loads often rather than big fills less frequently. Wood should be loaded in a front to back direction, this helps air flow as well as reducing the risk of logs falling forward. Close the door gently after wood fire is reloaded.

OVERNIGHT BURNING

Warmbrite 140 does not support overnight burning due to the size of the firebox.

WOOD FIRE MAINTENANCE

CHECK YOUR WOOD FIRE REGULARLY

Initially, we recommend you check your flue system at least once per month. After the first few months you will notice a pattern of soot and creosote build up and you can then determine an inspection interval for checking soot and creosote build up that is suitable for your wood fire installation.

Other checks, as listed below, should be carried out at least twice per year. If you notice anything wrong at any time it should be repaired immediately. Never use a wood fire that is in any way damaged or has a damaged flue.

1. Check your flue system for build up of soot or creosote and for signs of damage to joints.
2. To check flue outlet remove top of baffle by lifting and pulling out at end. Use a flashlight to check flue outlet. Clean and repair as necessary. Always replace top baffle before relighting stove.
3. Check that glass is not cracked or chipped and that the sealing rope is in good condition. Replace as necessary.
4. When the room is dark, use a strong flashlight to check the sealing of the wood fire at the edge and corners for leaks. Any leaks or cracks found should be repaired with fire cement or damaged parts should be replaced with genuine spare parts.
5. During periods in inactivity or infrequent use, regularly alternate the position of the flue damper. We also recommend placing a silica bag in the firebox to absorb any moisture which may cause rust.
6. Check that wood fire door is tight and well sealed when closed. Place a strip of paper into the wood fire and close the door, try to pull out paper. You should feel some resistance to your pull, check several points around the door. If it pulls out too easily, replace the rope and seal in place with a suitable high temperature sealant.
7. Check baffle plate and firebricks. Baffle plate should be replaced if a hole appears in the surface of the plate. Firebricks should be replaced when they start to crumble or the firebox is exposed.

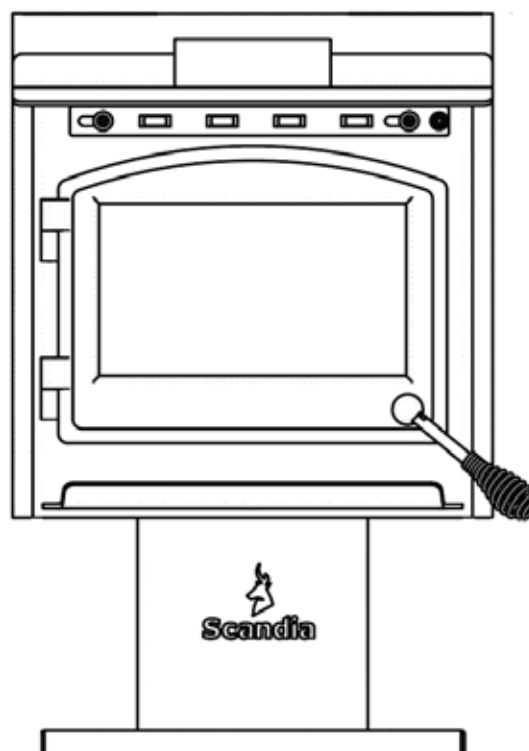

WOOD FIRE MAINTENANCEcontinued

ASH REMOVAL

When the stove is out and completely cold you may remove the ash using an ash vacuum or a steel bucket with a lid and shovel. Place a cover over the bucket so that when removing the bucket the ash does not blow about your house.

CARE OF GLASS

At times, especially when the air controls are turned to low settings or when damp wood is used, the wood fire glass will blacken. This is caused by fuel that is not completely burnt, but the build-up on the inside of the glass will normally burn off when a good hot fire is established in the wood fire.

There may be times however when you need to clean the glass. To do this, use a soft cloth and a non-abrasive glass cleaner. Only ever clean the glass when the wood fire is cold. For best results select from Scandia's range of glass cleaning products. When loading fuel into the wood fire, always make sure it is not protruding out through the door opening, as this may break the glass when you close the door. This is especially relevant when loading logs. Always close the door gently.

If the glass does crack when the wood fire is lit, let the fire die out. Do not open the door until the wood fire has fully cooled. Replace the glass with the specified replacement part before re-using the wood fire.

DOOR ADJUSTMENTS

Door closing tension adjustment - As door seals age the seal beds into the fire body, this will allow air to be drawn in any gaps created. Remove the grub screw from the door handle shaft on the inside of the door, this will allow the handle to rotate 360°. Rotate the handle 1 full turn anti-clockwise and shut the door. Repeat this step until the door offers a little resistance to close. Replace the grub screw. Over tightening may cause the door to distort and break the glass. If the door is at maximum adjustment this generally means the door seal will need replacing.

REPLACING PARTS

Always use genuine replacement parts. Only ever make replacements when the wood fire is cold.

All replacement parts can be ordered from www.scandiastoves.co.nz

SURFACE FINISH

To clean your fire wipe lightly with a damp cloth or dust with a duster. Some cleaning products may leave stains on the wood fire surface. Never use abrasive cloths as these may scratch the surface; take caution when using microfiber cloths as they can leave swirl marks if used in a circular motion. Painted wood fires can be re-painted by using a good quality, high temperature wood fire paint. When re-painting, make sure there is plenty of ventilation and follow the manufacturer's instructions. Allow the paint to fully dry before lighting the stove and allow extra ventilation for the first couple of fires as some fumes may emit from the stove as the paint cures.

Scandia high temp enamel is available at your local Scandia retailer.
Visit www.scandiastoves.co.nz for details.

TROUBLE SHOOTING

Many people under estimate the importance of using a professional installer with experience in wood heating who adheres to Australia and New Zealand Standards to install their wood fire.

If you are having issues with your wood fire not working the way you think it should, we implore you to speak to your installer first; they can help you with issues such as burning too much or too little wood, smoke in the room when you open the door, blackened glass or build-up of creosote during use. A professional installer can also provide guidance on whether the problem is a manufacturing issue in this instance we will work with them to resolve any issues as soon as possible for you.

It is important to remember that all flue installations must be compliant with Australia and New Zealand Standards. A fire installed with a non-compliant flue configuration will not perform as advertised or as tested.

FIRE NOT BURNING

A wood fire not burning is generally caused by either a shortage of air and/or incorrect or damp fuel.

If fuel is not the problem check:

-
1. That the air controls are opened.

 2. There is no blockage in the flue system.

 3. That the open end of the flue is above the height of any nearby obstructions.

 4. That there is a sufficient air supply into the room and that this supply is not being taken by an extractor fan.

GLASS BLACKENS

Glass usually blackens when:

-
1. The fuel is not being burned efficiently because of starvation of air.

 2. Bad quality or damp fuel is being used.

Please note: For optimum efficiency always use a good quality dry softwood.

SMOKE IN ROOM

If the wood fire is properly installed it should not emit any smoke into your room. Should this happen, check that your room is not air tight. This can easily be checked by opening a door or window. If the smoking stops you need to provide an additional air supply into the room. If this is not the problem, check if your chimney is blocked or obstructed and that you are not getting a down draught caused by the location of the open end of the flue pipe or chimney.

If the problem persists contact your installation company and ask them to get your chimney and stove installation checked.

FIRE BURNING TOO QUICKLY

This is usually caused by too much draught or air.

-
1. Firstly try reducing the air supply to the wood fire by closing down your air controls, if this fails then you may have to adjust the door or you may have damage to the sealing.

 2. Close a thin strip of paper in the door, check to see if the paper stays in place or pulls out. If the paper pulls out easily you may need to adjust or replace the door seal.

 3. Check to see if the glass moves within the door frame. If it does you may need to tighten the glass retainer screws.

 4. Check the condition of the door sealing rope and the glass seal tape.



See video at:
https://www.youtube.com/watch?v=nT-V_zL4jeg

TROUBLE SHOOTINGcontinued

CHIMNEY FIRE

Chimney fires occur when soot and creosote that have built up in the flue system ignite. If the wood fire is operated properly and the flue checked and cleaned regularly then chimney fires should not occur. These fires can be very dangerous and must be avoided. Try to maintain good, hot fires in the wood fire whenever possible and at least once in every firing open the air controls and allow the wood fire to burn on full for a short while until the entire fire bed is glowing red.

Check your flue system regularly for build-up of soot and creosote and clean as necessary. Chimney fires can be detected by sparks coming from the top of the chimney, a roaring sound coming from the area of the stove or chimney or vibration in the stove or chimney. In the event of a chimney fire, close the air controls, evacuate the building and call the fire department. Do not relight the stove after a chimney fire until the stove and flue have been checked and any necessary repairs have been carried out.

WARRANTY

SCANDIA LIMITED WARRANTY

This limited warranty is given by Scandia Heating (Aust) Pty Ltd (ACN 005 868 093) (Scandia or we) to the original retail purchaser (you) of the wood fire to which this Warranty applies.

Our goods come with guarantees that cannot be excluded under the New Zealand Consumer Law. You are entitled to a replacement or refund for a major failure and for compensation for any other reasonably foreseeable loss or damage. You are also entitled to have the goods repaired or replaced if the goods fail to be of acceptable quality and the failure does not amount to a major failure.

The benefits that this Warranty provides are in addition to other rights and remedies available to you under the New Zealand Consumer Law. This Warranty does not limit those rights and remedies.

SCOPE OF WARRANTY

If a defect in material or workmanship appears in the following parts within the corresponding warranty period after the date of the original purchase, such as to make the wood fire unfit for normal home use; and you comply with the requirements below regarding making a claim, then, subject to the exclusions below, we will replace or repair the relevant part or (at our option) replace the entire wood fire with the same or comparable model.

PART	WARRANTY PERIOD
Firebox	10 Years
All other parts (Including fans, other electrical items, top baffles, firebrick retainers)	1 Year

To the extent permitted by law, our liability under this Warranty is limited to this replacement or repair obligation.



IMPORTANT

For this Warranty to apply, you must fully complete the Warranty Registration Form via scandiaheating.co.nz/warranty. Alternatively you can complete the Warranty Registration Card and mail it to our mail address (below) within 30 days after the original purchase. By completing this form, you also agree that, to the extent permitted by law, our liability to you on any basis in relation to the wood fire (other than under the New Zealand Consumer Law) is limited to our obligations under this Warranty.

WARRANTYcontinued

EXCLUSIONS

This Warranty does not apply:

1. Where the defect is not due to the original design or manufacture of the part (including where the wood fire, part or accessory has been subject to accident, abuse, alteration, misuse or neglect or has been installed, inspected, operated or maintained negligently or not in accordance with applicable local laws and regulations and the manufacturer's printed instructions, if any)
2. Where the firebricks, top baffle or fibreglass seal have not been replaced after becoming damaged or worn
3. To any accessories or optional parts
4. To any glass, paint, firebrick, fibreglass seal sold or used with the wood fire
5. To any surface rust which may occur in transit, storage or use.
This includes installations in close proximity to coastal areas and salt water which may cause rust to the appliance.

HOW TO MAKE A CLAIM

Any claim under this Warranty must be in writing to our mail address below. It must be sent within the applicable warranty period and must state:

1. The model and serial number of the wood fire
2. The place, price and date of purchase
3. Reasonable details of the defect

To obtain replacement or repair under this Warranty, the wood fire must be returned to the original place of purchase (and collected from there once the replacement or repair is complete) at your cost. Scandia will not be responsible for any associated freight, disconnection or re-installation costs (including labour costs). Scandia will only be responsible for transport of the wood fire from the original place of purchase to Scandia's premises (and back), and replacement or repair in accordance with this Warranty.

REGISTER YOUR PRODUCT



REGISTER ONLINE

Register your product warranty online by visiting:

www.scandiastoves.co.nz/warranty

Your data will be used by Scandia to provide you with information about your purchase upon request.



REGISTER BY MAIL

Alternatively, please complete the attached warranty card within 30 days of installation and return to:

Scandia Heating (Aus) Pty Ltd.
58 Access Way, Carrum Downs
Victoria, Australia, 3201.

WARMBRITE 140 LE EXPLODED DIAGRAM

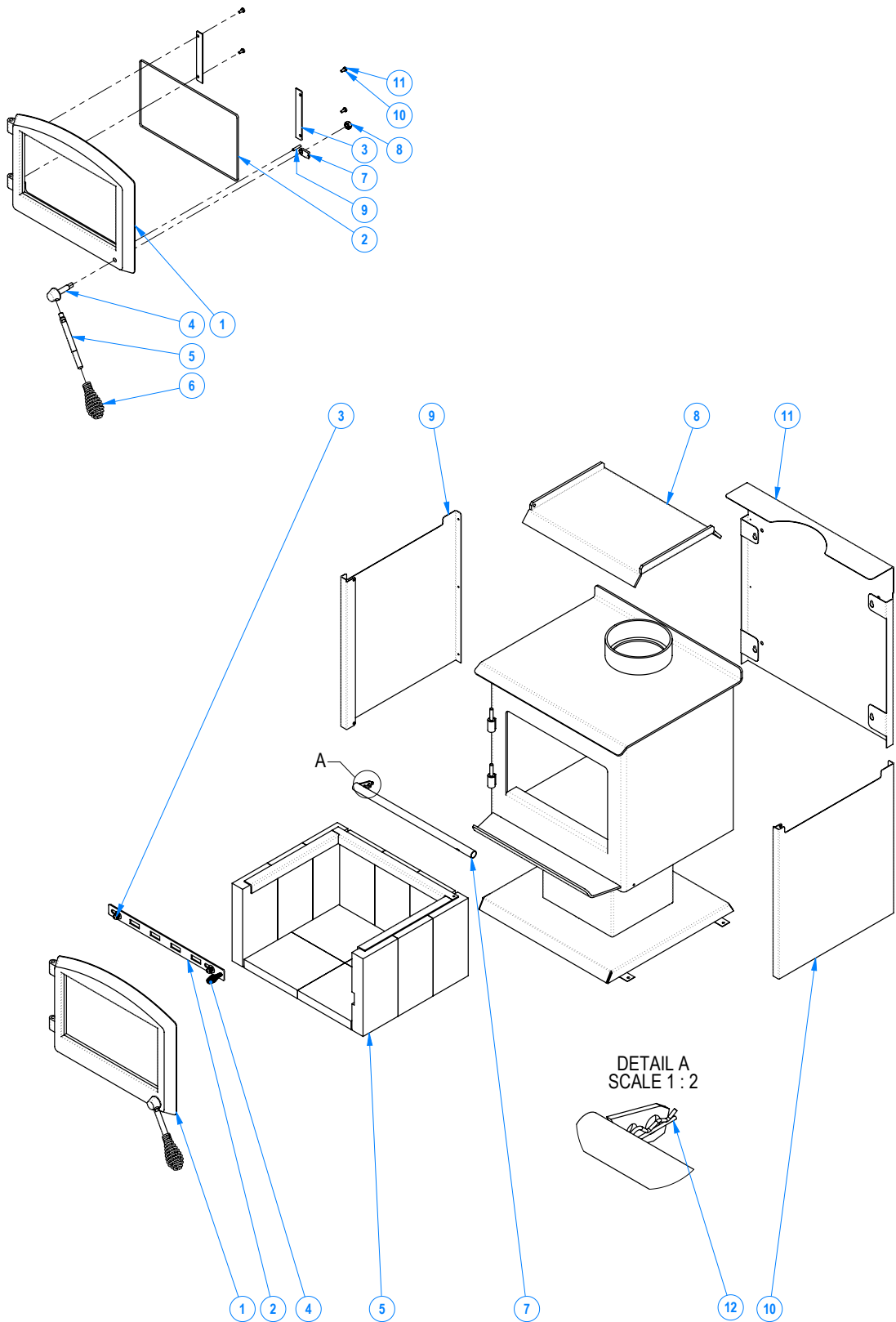

WARMBRITE 140 LE SPARE PARTS LIST

LEGEND	SCANDIA PART NUMBER	DESCRIPTION	QTY
1	DOOR		1
2	SP14019	AIR SLIDE BODY WB140	1
3	SG031300118	KIT FASTENERS AIR SLIDE	2
4	SP00010	HANDLE SPRING AIR SLIDE WB140	1
5	SP14008	SET FIREBRICK WB140 S1&2 KA425R	1
6	SP14007	RETAINER BRICK WB1402/KA425R	1
7	SP14028	WB140LE, SECONDARY AIR TUBE	1
8	SP14031	WB140LE, BAFFLE PLATE	1
9	SG030701092	WB140LE, SIDE PANEL, LHS	1
10	SG030701093	WB140LE, SIDE PANEL, RHS	1
11	SG030701094	WB140LE, REAR PANEL	1
12	SPSTY005	AIR TUBE LOCATING PIN	1

LEGEND	SCANDIA PART NUMBER	DESCRIPTION	QTY
1	SP14027^DOOR	WB140LE, DOOR CASTING, MACHINED	1
2	SP14009^DOOR	WB140LE, DOOR GLASS	1
3	SP14015^DOOR	WB140LE, GLASS RETAINER	2
4	SP14016^DOOR	DOOR HANDLE SHAFT	1
5	SP14013^DOOR	DOOR HANDLE ROD	1
6	SP00008^DOOR	DOOR HANDLE SPRING	1
7	SP00020^DOOR	DOOR LATCH	1
8	SG031300010	HEX NUT LOCK BLACK ZINC, M10	1
9	SG031300188	GRUB SCREW, FLAT POINT, M5x25,	1
10	SG031300074	Flat WASHER BLACK ZINC, M5	4
11	SG031300021	PAN HEAD PHILLIPS BLACK ZINC, M5 X 12	4

Head Office
58 Access Way,
Carrum Downs VIC 3201
Australia

Scandia Heating (Aust) Pty Ltd
(03) 8579 5900
info@scandiaheating.com.au
www.scandiaheating.co.nz





Scandia

www.scandiastoves.co.nz
www.scandiastoves.com.au